

Instruction Sheet

ADVANCED CT LASER COLLIMATOR for CASSEGRAIN TELESCOPES

Thank you for purchasing the state-of-the-art HOTECH Advanced CT Laser Collimator instrument. This instrument uses the most advanced laser optical technologies achieving excellent collimation in a very short distance. Collimation is a method to align your telescope's optics. The laser collimator makes the collimation process more efficient and it can increase collimation accuracy with the guide of the instrument. Your telescope is aligned at the factory, but harsh handling during shipping can sometimes misalign collimation. Some telescopes are not well collimated when shipped. Misaligned collimation can mean decrease of optical efficiency thus introduces poor image contrast, astigmatism, and blurry images. The following describes how to collimate your Cassegrain style telescope with the aid of the Advanced CT Laser Collimator to optimize the optical efficiency of your telescope.



Please read the entire instruction sheet before using your Advanced CT Laser Collimator

Be aware of the following as you use your Laser Collimator:

Only turn ON your laser(s) when you are going to use it. Turn ON your laser(s) with adult supervision for collimating the telescope purpose use only. Do not point the laser(s) directly or indirectly via reflected glass or mirror other than your telescope to anyone's eye. We will demonstrate the laser collimation on a Schmidt Cassegrain Telescope which applies to collimating all Cassegrain style telescopes in the similar way. All lasers on the collimator are class II (<1mW). For additional information, please visit our website, www.hotechusa.com, or write us at info@hotechusa.com.

Collimation Basics You Must Know Before You Start

What to Adjust:

The only user accessible alignment component on a Cassegrain Telescope (includes CT, SCT, RC, Maksutov.) is the secondary mirror alignment screws. Therefore, you only need to adjust the three alignment screws located at the front of the telescope behind the secondary mirror (see illustration below). The limited adjustment makes the collimation simple to adjust but difficult to achieve. For ease of manual adjustment, we recommend replacing the stock alignment screws to a larger thumb screws for easier access and finer feel adjustment.

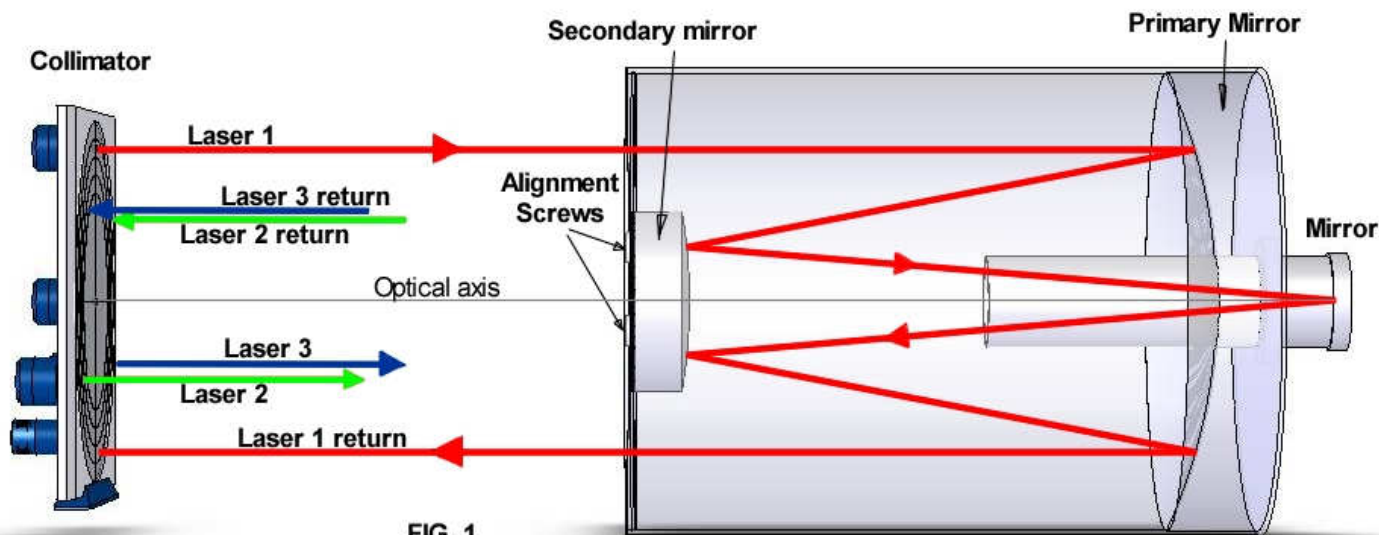

How the Collimator Works:

The Advanced CT Laser Collimator samples your entire optical system (primary, secondary mirror, and the eyepiece axial position) with a simulated large aperture flat-wavefront light source generated by three parallel lasers positioned behind the target plate. The target plate provides a clear view of the optics' alignment condition when the three lasers are reflected back on the target (FIG. 1). It is extremely critical that the lasers must point square (co-aligned) with your primary mirror for an accurate reading. It is just like looking at a distant star and centering the star in the eyepiece FOV during a star test, except the star is about 3 feet in front of your telescope.

To ensure accurate aiming, you must use the crosshair laser emitting from the center of the collimator as a guide to the center point on your primary mirror (FIG. 2A), and the reflected crosshair from the telescopes primary mirror to the center point of the target (FIG. 2C). Please expect to spend most of the time on iterating the aiming adjustment. Be patient and consistent, the reward is beyond your imagination.

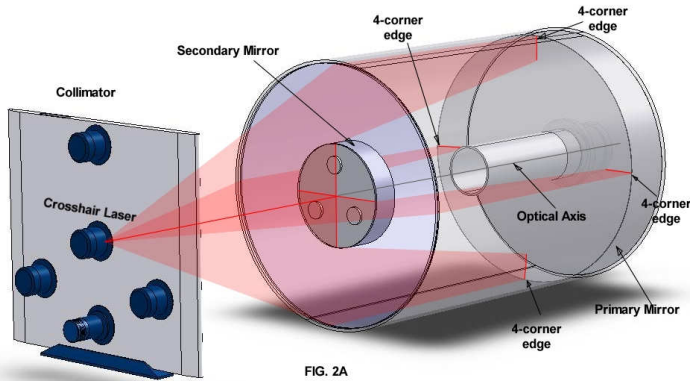

FIG. 2A

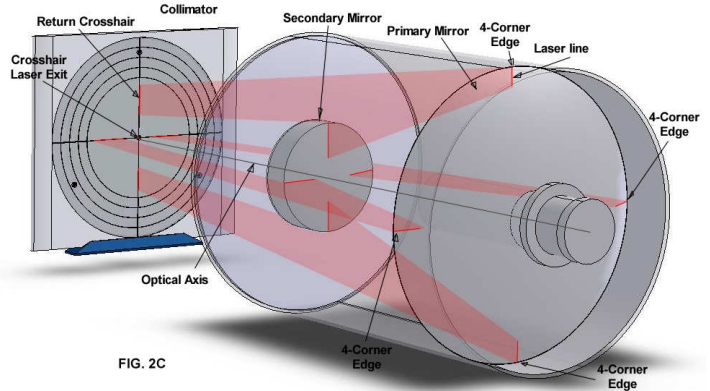

FIG. 2C

How to Adjust Collimation on Your Scope:

You can collimate your telescope at almost any position (e.g. telescope 20 deg. up) as long as both the collimator and the telescope point square at each other. Once the lasers and your telescope are co-aligned, adjust the necessary secondary alignment screws gently to move the three projecting laser dots to line up on the same track on the target plate.



Process Flow Chart:

1. Setup collimator distance
2. Install reflector in eyepiece
3. Aim collimator at telescope (FIG. 2A)
4. Aim telescope at collimator (FIG. 2C)
5. Adjust secondary to bring the three laser dots on the same track

Package Content:

- 1 x Premium Soft Carrying Case
- 1 x Advanced CT Laser Collimator
- 1 x SCA Reflector Mirror (1.25" or 2")
- 1 x 3V, CR123 Lithium Battery
- 1 x Paper Ruler
- 1 x External alignment Tab Strap (in bottom layer)
- 3 x Alignment Tabs (in bottom layer)
- 1 x Users Manual (in cover pocket)



1.0. Setting Up the Laser Collimator on the Tripod

1.1. Where to setup the telescope and the collimator

Station both the collimator and the telescope on a solid ground (no carpeted, wooden floor, or any other surface that will flex or vibrate). It is required to have both stationed on the same ground floor.

1.2. Setup the collimator on the tripod

- Fasten the laser collimator on the recommended fine adjustment stage with the thread knob on the mount to the $\frac{1}{4}$ -20 screw hole at bottom of the rail base.
- Further lock the thread knob with the fly wheel lock.
- Use the standard $\frac{1}{4}$ -20 screw on your tripod to fasten the fine adjustment stage.



2.0. Getting Familiar with Your Instrument

2.1. Installing the battery

Unthread the battery compartment cap then insert the CR123 lithium battery with the positive side up (tip side up) then close the battery cap.



2.2. Switching the laser to the proper mode

Position the collimator on a tripod about 4 feet distance from a white wall with the target side facing the wall. Rotate the rotary knob on the top right corner of the collimator to activate different laser modes. You will see the projecting laser patterns on the wall activating at various positions.

Mode 0: Unit off.

Mode 1: Crosshair laser ON.

Mode 2: Crosshair laser and three alignment lasers ON.

Mode 3: Crosshair laser, three alignment lasers, and target backlight ON for night use.

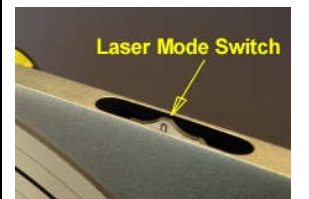

Other modes:

DT: Three alignment lasers ON.

BL: Backlight ON.

1L: Crosshair laser and backlight ON.

CL: Three alignment lasers and backlight ON.

This is a logic switch. Other modes are for visual preferences that will not affect the collimation process. Please use the recommended mode in each procedure for best result.

2.3. Gross pointing adjustment

Switch the laser to Mode 2, lift the tripod and move the collimator with the tripod at various distances from the wall to see how the crosshair expands and reduces in size in reference to different distances.



2.4. Fine adjustment stage adjustment

Place the tripod with collimator back on the ground. Find and adjust the corresponding knob on the stage in the following.

Vertical Adjustment:

- The large knob, on right, is for quick rough adjustment in the vertical direction. You can loosen the large knob and level the laser first.
- The forward small knob is for fine adjustment in the vertical (up/down) direction. You must lock the large knob first in order to make the fine adjustment with the forward knob.

Horizontal Adjustment:

- The left side small knob is for fine adjustment in the horizontal (left/right) direction.



3.0. Adapting the SCA Reflector Mirror:

3.1. Adapting the SCA Reflector Mirror on your focuser

If the purpose of the night is visual observation, you may adapt the SCA Reflector with the diagonal, on the condition that it does not introduce optical aberrations (center of the field is not shifted if the diagonal rotates in the drawtube). However, if photography or CCD imaging is planned, it is best to adapt the SCA Reflector without the diagonal.

For an installation video guide of the SCA mechanism, please review our YouTube videos at www.YouTube.com/hotechusa under Installing and Uninstalling HOTECH SCA Laser Collimator.



4.0. Do You Need the External Alignment Tabs?

- It is very critical to have the lasers co-aligned with your primary mirror optical axis for an accurate diagnosis of your telescope. To achieve this, you use the projecting crosshair on the collimator to center point your primary mirror by referencing the 4 corners on the mirror to the crosshair lines. Then you use the reflected crosshair lines projected on the primary mirror to center point back to the target.
- The crosshair lines from the collimator are precisely 90 degrees apart. You will have to find or create the 90 degrees markings on or close proximity to your primary mirror for collimator aiming reference.
- It is ideal to edge-mark the 4 corners (90 degrees apart) on the primary mirror or the cell holder if it is accessible. For those scopes that do not have accessible open truss configuration, please refer to the following solutions.

4.1. Visible components close to the primary cell – no Alignment Tabs needed

Most Meade SCT telescopes have at least 4 visible mounting screws at the base of the telescope 90 degrees apart, protrude into the OTA. Identify the position of these 4 screws by looking from the front of your telescope. You will rely on these screws as your collimator aiming guide. You will not need the external Alignment Tabs for your telescope if the mounting screws are visible. Please proceed to step 5.0.



4.2. No visible components close to the primary cell – require Alignment Tabs

If there are no visible markings or objects in close proximity to the primary mirror that are 90 degrees apart, use the included Alignment Tabs as your alternative external aiming guide.



4.3. Setting up the Alignment Tabs

4.3.1. Measure and mark the 4-corner distance on your OTA

- Use the included paper strip ruler and wrap it on the OTA closest to the primary mirror position.
- Mark the position where the paper strip intercepts to a full diameter wrap.
- Remove the paper strip. Line up the start of the strip with the marked position and fold it twice to find the $\frac{1}{4}$ length of your OTA diameter.
- Wrap the paper strip back on your OTA, and use a marker or pencil to mark three consecutive positions 90 degrees apart on your OTA.

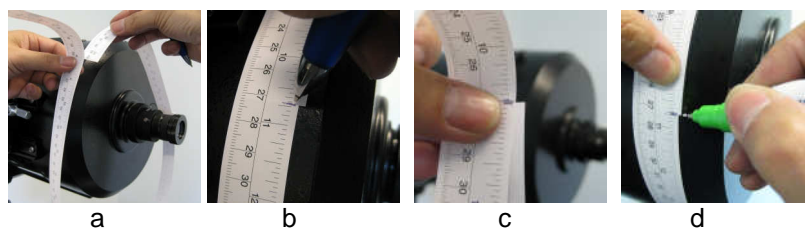

4.3.2. Installing the Alignment Tabs

- Wrap and tighten the black strap around the OTA next to the 3 indexed markers on the OTA.
- Insert the base of three Alignment Tabs at the corresponding pre-marked position.
- Pre-adjust the Alignment Tabs to make it tangent to the OTA.

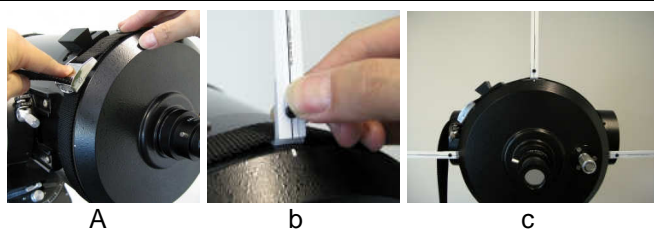

4.3.3. Lining up the Alignment Tabs normal to the OTA

It is important to keep the Alignment Tabs tangent to the OTA at each marked position for an accurate aiming reference. Use the crosshair laser on the collimator to help you achieve this step.

- Position the laser collimator at about the same center height of your telescope. Switch to Mode 1 to activate the crosshair laser.
- Aim the crosshair directly at the visual back of your telescope to project the crosshair on the 4-edge marks. Check the reflection of the crosshair laser on the target from the SCA reflector and adjust both pointing of the collimator and the telescope to bring the reflected crosshair back to the center of the target on the collimator.
- Iterate the process until both the projecting crosshair on your telescope is on the 4-edge marks and the reflected crosshair is in the center of the target.
- Adjust the Alignment Tabs to line up with the crosshair to the end of the Alignment Tab. This will ensure the tabs are pointing normal/tangent to the OTA. You will rely on these tabs during collimation. Switch to Mode 0 to turn off the laser collimator.

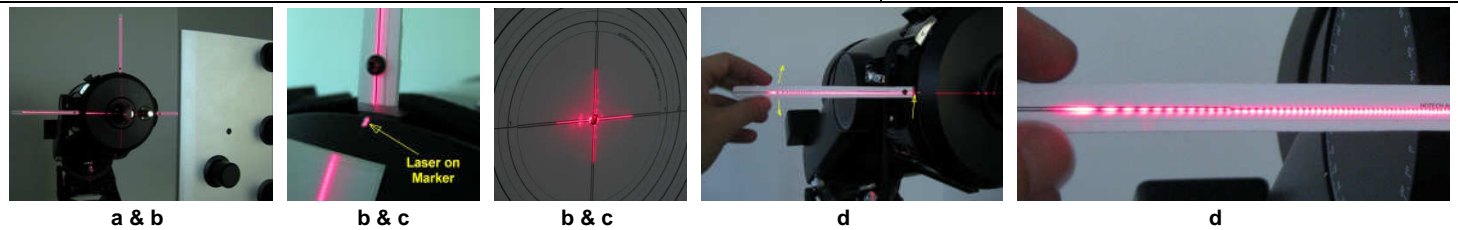
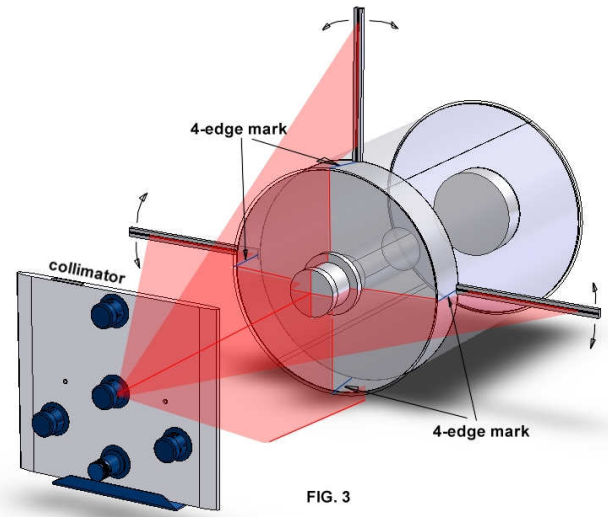

5.0. Positioning the Laser Collimator at the Proper Distance

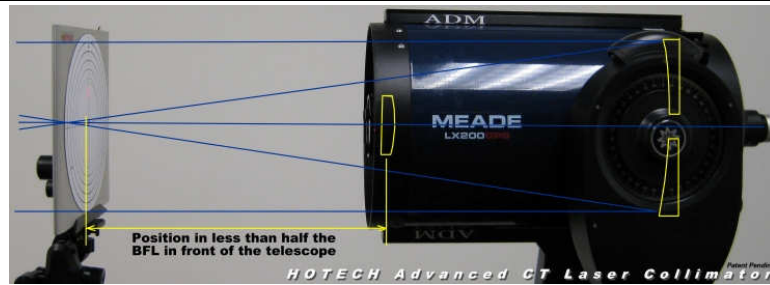

The distance between the laser collimator and your telescope varies depending on the diameter and focal distance of your telescope. In general, the longer the distance away from your telescope, the higher accuracy you will achieve. And in practice, any distance beyond the focal distance will be sufficient for your calibration for both visual and practical adjustment purposes. In this procedure, we will help you identify the best collimating distance for your telescope.

5.1. Determine the distance between the laser collimator and your telescope

- Position the collimator in front of the scope to about equal length of the OTA with the target display facing the telescope (photo above).
- Switch the collimator to Mode 1 (crosshair laser only).
- Roughly aim the crosshair toward the telescope.
- Experiment with the proper distance by slightly lifting the tripod, with the collimator on it, and move the collimator slowly toward and away from the telescope while keeping the reflected crosshair on the target plate. Don't worry about getting the crosshair perfectly concentric in the center of the target at this point. You will see how the crosshair contract and expands in size on the target plate in relation to the distance adjustments.
- Move the collimator to where the crosshair converges to the smallest size. This is the back focal point of the primary mirror. Now begin to move the target towards the telescope until the crosshair expands to the size of the first ring? on the target.
- Firmly position the tripod at this distance. This will be your collimating distance.

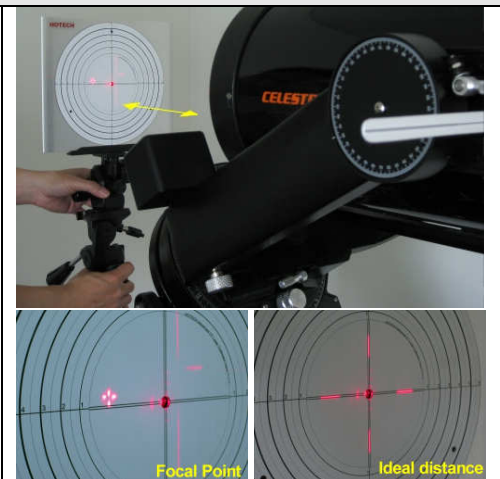

6.0. Achieving Co-Alignment on the Collimator and Your Telescope

This is the critical stage where you must co-align the collimator and your telescope for an accurate reading of your optics alignment. DO NOT use the center of the secondary mirror assembly as your crosshair centering reference because the secondary mirror might not be center positioned on the corrector plate, and the telescope might not be pointing straight at the collimator at this point. You can use it as a quick gross adjustment, but not for final aiming adjustment.

6.1.1. For telescopes using the internal screws as the aiming reference

- Check if the crosshair is visible on the internal screws.
- Aim the crosshair emitting from the collimator on your telescope's 4-corner referencing edges (the internal screws). Use the fine adjustment stage to refine the collimator aiming.
- Go to step 6.2 (next page)

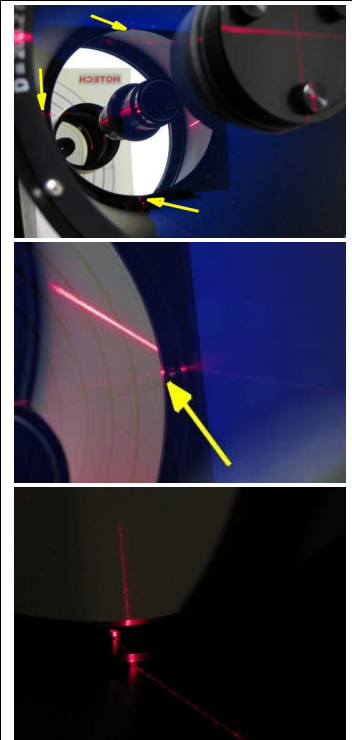
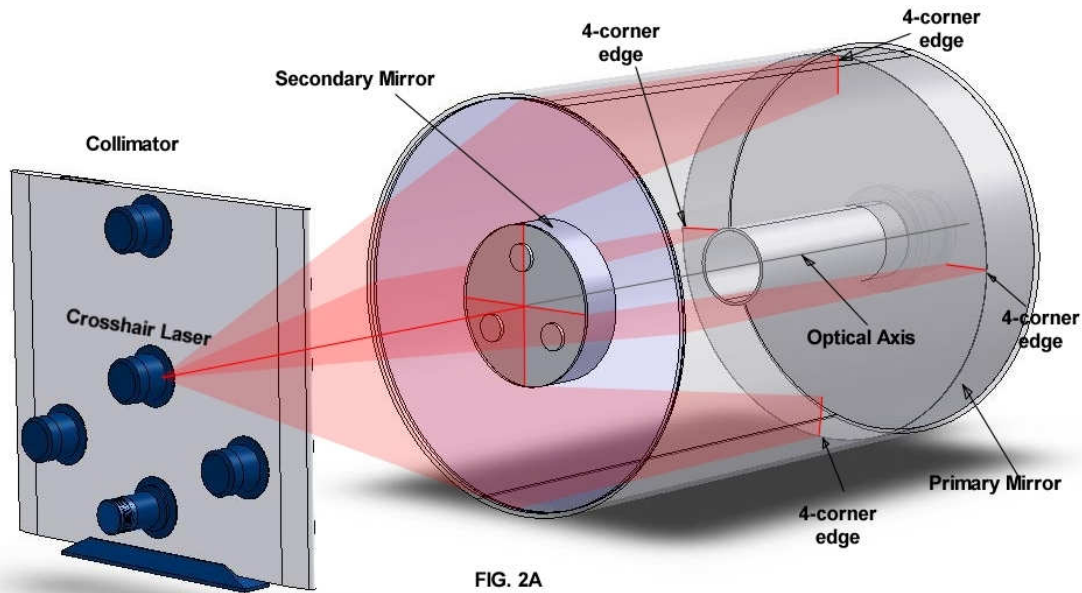

6.1.2. For telescopes using the Alignment Tabs as the aiming reference

- Check if the crosshair is visible on the three tabs.
- Point the crosshair as close to the center of the primary mirror, and wave your hand behind the Alignment Tabs to find the crosshair. If the crosshair is cropped beyond the tip of the stick, move your collimator further away from the telescope until you can see a portion of the crosshair projecting on the tip of the Alignment Tabs.
- Use the fine adjustment knob to refine the collimator aiming to line up with the three Alignment Tabs.

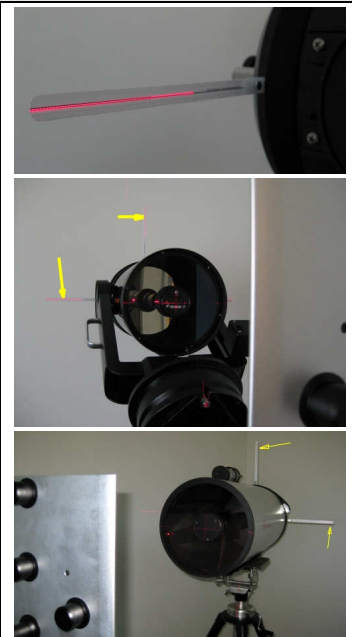
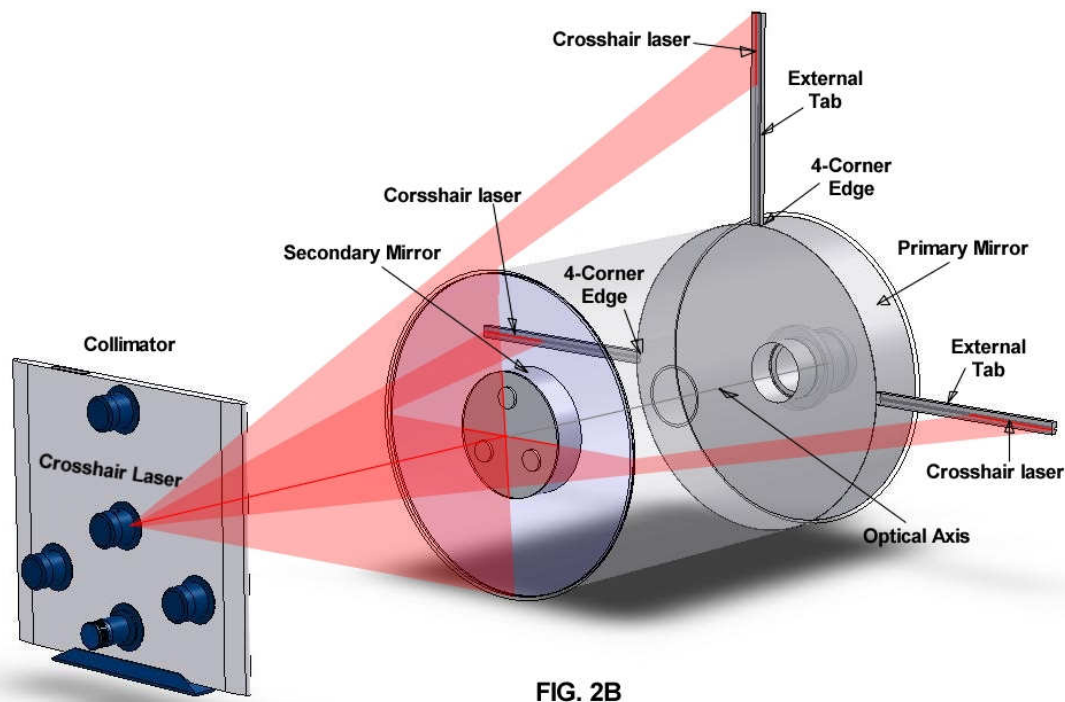

6.2. Aim your telescope back to the collimator

- a). Use the telescope's fine adjustment knob or the motor remote control to aim the reflected crosshair from your telescope back to the center of the target. You will need to line up the vertical and horizontal cropped crosshair lines with the cross line on the target plate. When it points square, the vertical and horizontal cropped crosshair lines will have symmetry length.

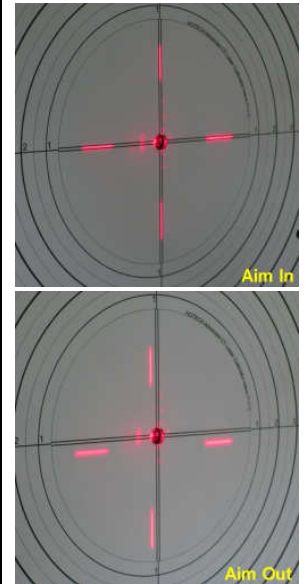
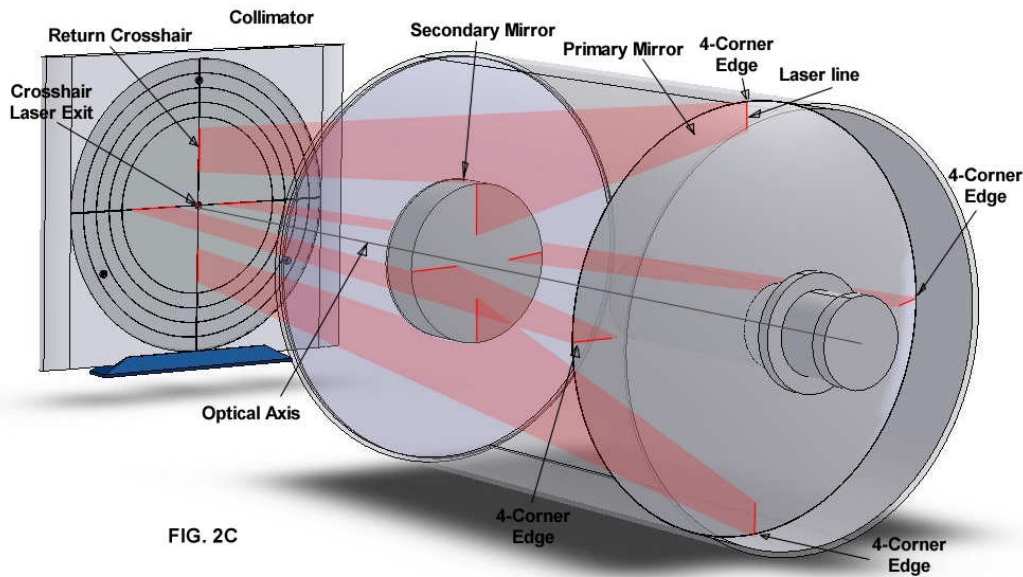

6.3. Co-alignment confirmation

Iterate step 6.0 until both conditions are met. This means both telescope and the collimator are pointing square at each other like looking at a distant star. Lock your telescope and you are ready to diagnose your optics.

7.0. How to Read the Diagnostic Result on the Collimator

With proper aiming in step 6, the collimator can accurately reveal any errors in your optical system by reading the center deviation of the three returning laser dots on the target plate.

7.1. Locate the three laser dots

- Switch to Mode 2 or Mode 3 (three lasers and the crosshair, or Mode 3 with backlight).
- Verify if the crosshair is still center pointed on both the target plate and the Alignment Tabs or screw markers?.
- Locate the three laser dots on the target plate.
- If the three laser dots are visible on the target plate, go to step 8 to collimate your telescope.
- If the three laser dots are not visible or partially visible on the target plate, please continue to the following possible scenarios.

7.2. The SCA Reflector is not properly adapted

- The SCA Reflector represents the axial alignment of your drawtube (eyepiece holder). You must install it correctly (square in your drawtube) in order to represent the axial position of your eyepiece or CCD camera position. This axial position of your drawtube is directly related to the alignment axis of your entire optical system (telescope). Please refer to step 3 for proper SCA Reflector installation guide.
- If you have verified the correct installation, and still exhibit the same condition, continue to the next step, otherwise go to step 8.

7.3. The SCA Reflector is not positioned at the focal plane

- This can happen if you were initially using the diagonal for viewing, thus the focal plane is at the diagonal extension distance. After you remove the diagonal for collimation, without any focusing adjustment, it will move the three laser dots out of the target screen. If you do not use the diagonal, continue to the 7.4.
- Adjust the focus to bring at least two laser dots into the full view of the target plate. Adjust the focus in one direction first to see if any of the laser dots are moving toward the center direction of the target. If the laser(s) is moving or expanding away from the center of the target, reverse the focusing direction to bring at least two laser dots into the full view of the target plate. Go to step 8 to collimate your telescope.

7.4. Your telescope is grossly out of alignment

When your telescope is grossly out of alignment, the laser dots may be completely out of the target screen. You may start the collimation process to see if you can bring the three laser dots into the target screen. Proceed to step 8.0.

8.0. Collimating Your Telescope

The main objective in this step is to bring the three laser dots on the same track on the target. You will need to constantly check the crosshair laser (step 6) for both telescope and collimator aiming on each iterated adjustment. Here are few simple precautions you need to follow while adjusting the secondary mirror alignment screws located on the back of the secondary mirror assembly or front center of the telescope.

- Never touch the central screw which holds the secondary mirror.
- The three screws must be turned in moderation, no screw being over-tightened or totally unscrewed.
- When a screw is turned, the other two must be tightened. Never keep more than one screw loose.
- Each turn on the screws must be small. Reference the screw adjustment to the displacement of the three laser dots on the target plate to determine your adjustment level.

8.1. Collimate your telescope

- Adjust the alignment screws to bring the three reflected laser dots on the same track on the target.
- If you cannot bring all three laser dots into the target view because the dots are too far apart, adjust the focus to merge the three laser dots at approximate distance between track 4 & 5.
- Check for proper aiming of the collimator and the telescope in step 6.
The telescope might shift in position if you put too much pressure during secondary mirror adjustment. You must double check if you have nudged the telescope pointing out of the co-alignment.
- Iterate step 8.1 until both the three laser dots are on the same track on the target and the aiming of both the collimator and telescope are still co-aligned.

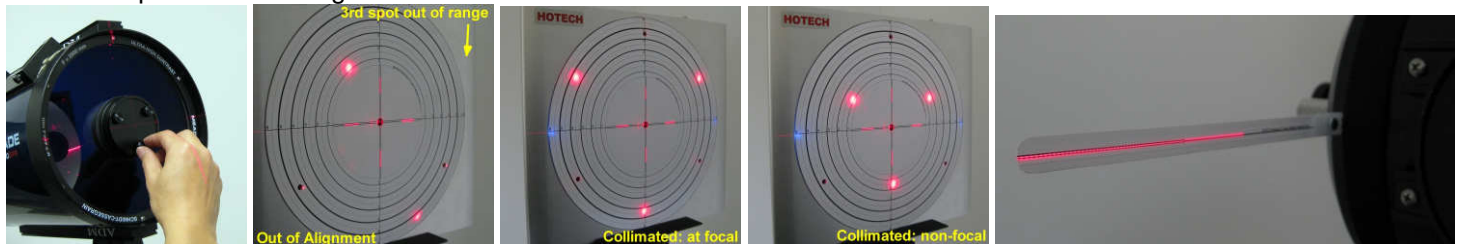

9.0. Verifying and Fine Tuning Your Collimation

9.1. Star test to verify the adjustment

- On your first observing session, star test the telescope to verify the adjustments.
The Advanced CT Laser Collimator should bring excellent collimation to your telescope. Minor adjustment might be required due to temperature variation during a long observing session.
- Use the intra-focal and extra-focal technique with a high magnification eyepiece on a magnitude 0 to 1 star to determine the result. Fine tune the collimation if necessary. Please refer to the Star Collimation manual for detail. You are ready for observing after final touch up.

10.0. Possible Scenarios if the Laser Collimation Does Not Agree with Star Collimation

10.1. Both the collimator and the telescope were not co-aligned during adjustment

It is possible that during collimation (step 8), the co-alignment of the collimator and the telescope were slightly off causing an incorrect diagnosis. It is very critical to ensure both the collimator and the telescope are co-aligned to simulate the light path entering the telescope.

Do not adjust the collimation screws. Go to step 6 to verify the co-alignment of the collimator and the telescope and check if three laser dots still fall on the same track. If both conditions are met, your optical system is in good condition meaning they're all lined up well on the same optical axis. If not, continue to the next step.

10.2. The mirror-flop on your primary mirror focusing mechanism is causing the miscollimation

Due to machining tolerances on the primary mirror and improper greasing on the baffle, some telescopes exhibit more mirror-flop than others. A slight loose tolerance will cause major axial alignment deviation. The Advanced CT Laser Collimator is sensitive enough to pick up any deviation in step 6. Prior adjusting the secondary alignment screw, observe the shifting position of the three laser dots on the target by making two full turns clockwise on the focus knob, then reverse half turn. The shifting of the laser dots during the reverse turn tells how much mirror flop you have on your focusing mechanism.

If the displacement is more than 2 tracks spacing distance, we recommend attaching a higher grade focuser on your visual back for focusing adjustment and leave the built-in focus mechanism untouched.

10.3. The eyepiece drawtube or the visual back is not square to your primary mirror

We recommend replacing a new higher grade eyepiece drawtube or a focuser that has tip/tilt adjustment to correct the axial error. E.g. MoonLite CS model, <http://www.focuser.com/cgi-bin/dman.cgi?page=productdetail&plugin=dstore.cgi&product=CS>. We have found several older SCT scopes having poorly machined eyepiece/drawtube which is not square to the OTA. This may cause serious problem for imagers where the focal plane are also not parallel to the primary.